

The GANTREX **“double-crown”** RailLok™ series patent pending pad is specifically designed to perform integrally with the RailLok™ series clips for the soft mounting of rails.

A full range of pad widths is available to provide the very best technical solution for each individual application.

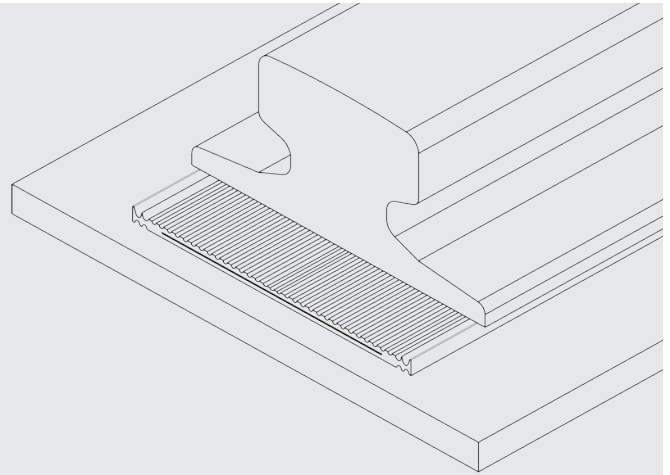

### GENERAL CHARACTERISTICS

The **“redesigned edge seal”** virtually eliminates the ingress of contaminants and water which can cause premature failure of the pad, rail and support structure. These seals also improve the compression caused by the nose of the clip, preventing pad movement when the pressure of the rail is released.

The updated **“design of the grooves”** avoids high stresses and resultant damage due to high loads, rail twisting and oscillation.

### SPECIFICATIONS OF THE PRODUCT RANGE

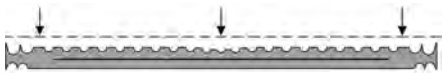
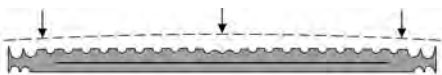
			
Flat Model	Estimated weight	Crowned Model	Estimated weight
	kg/m		kg/m
F80	0.7		
F90	0.8		
F95	0.9		
F105	1.0		
F115	1.1		
F120	1.2		
F125	1.2	C125	1.2
F130	1.3	C130	1.3
F140	1.4	C140	1.4
F150	1.4	C150	1.5
F155	1.6	C155	1.6
F170	1.7	C170	1.9
F175	1.8	C175	2.0
F200	2.1	C200	2.3
F220	2.3	C220	2.5

The values shown are nominal widths corresponding to the width of the rail foot. C200 is a crowned pad suitable for the DIN rail A100.

**MK9.0 RailLok™ double-crown** pad is supplied in rolls with standard lengths of 12 meters, tolerances on length is ± 50 mm.

Pad can be provided in various other lengths thanks to the flexibility with the extruded manufacturing process.

Nominal thickness of uncompressed pad is 7 mm.

Please contact Gantrex for more information on any GANTREX® product or for pad specification if your rail size does not appear in the table.

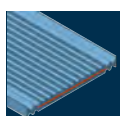

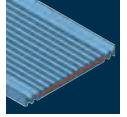

### TECHNICAL ADVANTAGES OF THE NEW GANTREX<sup>®</sup> PADS

#### **New features**

- Eliminate the ingress of dirt and water.
- Improve the compression created by the nose of the clip.
- Avoid high stresses and pad damage caused by crane oscillation and rail twisting.

#### **All old features have been maintained :**

- Distribute the wheel load over a larger surface area.
- Eliminate point load concentration and resultant fatigue stresses.
- Compensate for the uneven surface between the rail and its support.
- Reduce impact, vibration and noise.
- Eliminate fretting corrosion (wear) of the support surface under the rail.

### MATERIAL CHARACTERISTICS

- Material : synthetic rubber reinforced with a steel strip.
- Shore A hardness:  $75 \pm 5$ .
- Tensile strength : minimum 12.5 N/mm<sup>2</sup>.
- Elongation : minimum 250 %.
- Permanent set : < 20 %.

Resistant to : wear, shear and crushing, as well as oil, grease, ultra violet rays (and ozone).

Service temperature is between -25°C and +100°C. Gantrex selects the rubber depending on the customer's application. Please contact Gantrex to specify your operating temperature.

A noise reduction of approximately 10% and vibration reduction up to 48% can be expected.

### INSTALLATION INSTRUCTIONS

1. **MK9.0 RailLok<sup>™</sup>** pad is recommended for all installations, both indoors and outdoors. For better results, RailLok<sup>™</sup> series clips should also be used to fix the rail laterally in order to keep the pad firmly under the rail.
2. The upper surface of the supporting structure should be clean and free from oil, grease and any sharp or abrasive particles that are likely to damage the pad. Please consult Gantrex before a corrosion protection painting system can be applied on the supporting structure before the installation of the pad.
3. The pad should be laid in continuous lengths on the support surface, with the grooved side up, the ends butted tightly together and centered at a pair of rail clips. Rail pad should always be centered beneath the rail foot so that it is completely covered.
4. Pad joints should be at least 1 meter away from rail joints, adjacent girder joints or building expansion joints.
5. The minimum length of pad should not be less than 3 times the center distance between clips.
6. Pad stops should be considered at the ends of each runway and where the continuity of the support cannot be achieved and large gaps between adjacent pads may occur.
7. Do not use cleaning fluids or protective coatings which contain ketones or similar chemicals, as they may seriously damage the rubber pad.

Please consult Gantrex on any questions regarding installation.

*We reserve the right to discontinue or change specifications or design at any time without prior notice and without incurring any obligation whatsoever.*

